

Studies of Purification of the LHC RPC Gas Mixture

Status June 08

RG, MC, IG

Open issues from the 2000-2004 GIF ageing test

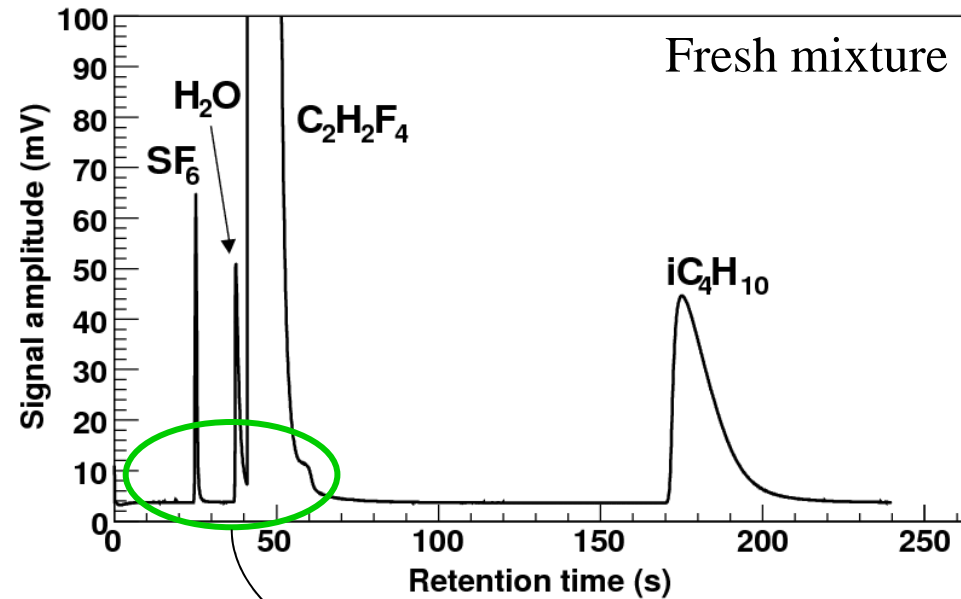

Purifiers: - better configuration (?)
- effectiveness
- lifetime
- regeneration process

Recirculation: which fraction (?)

A zoom of the same region for the mixture before and after the purifiers:

Not all extra peaks can be filtered, with any combination of the tested filters (signals 2, 4 remain)

It seems that the Ni filter produce or enhance one extra signal (number 8)

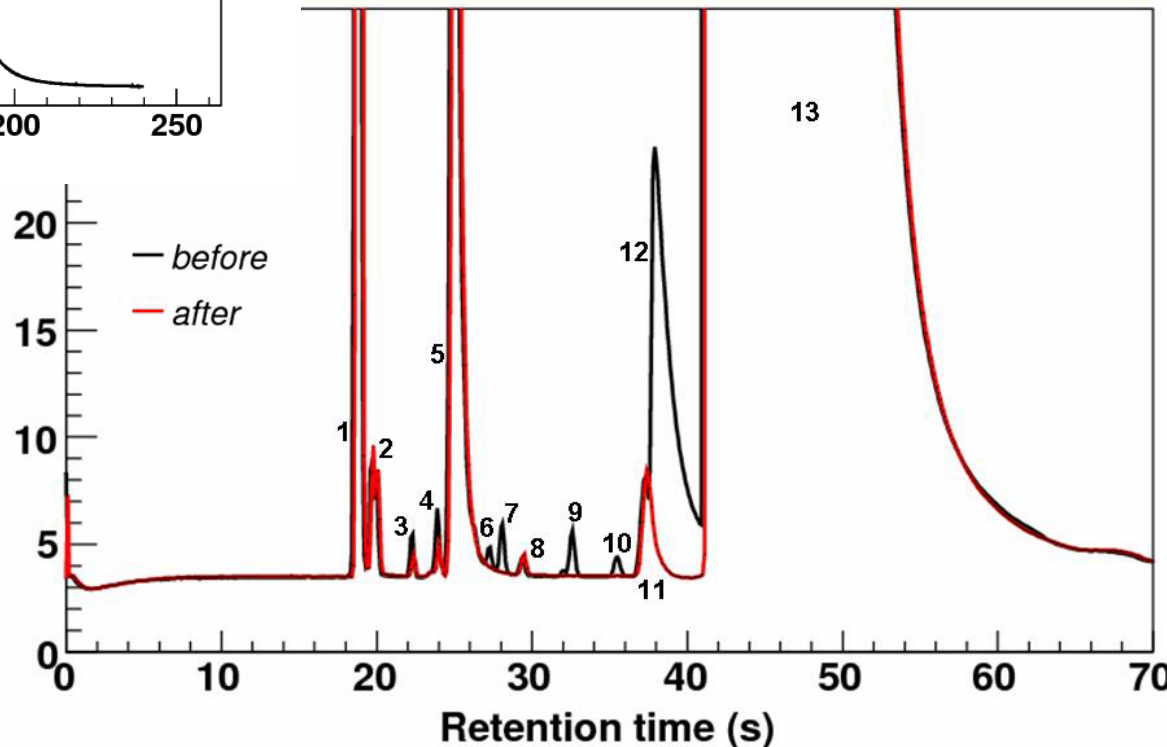

Open issues from the 2006-2008 ISR test

RPCs:

- *Real size CMS-RPC part of the normal production*
- 7 old DG (CMS-RB1) connected:
 -) 1 in open mode
 -) 6 in closed mode
- 10 new SG
- Temperature and Relative Humidity (Environmental + mixture) under control



Gas flow: 1 volume change / 2.5÷3 hour
HV constantly on at operating value
(9.6 kV @ 1020 mbar)
No radiation (cosmic ray only)

Gas re-circulation:

Test started with a re-circulation factor of about 70 %
After one month re-circulation increased
Since middle October stable at 90 %

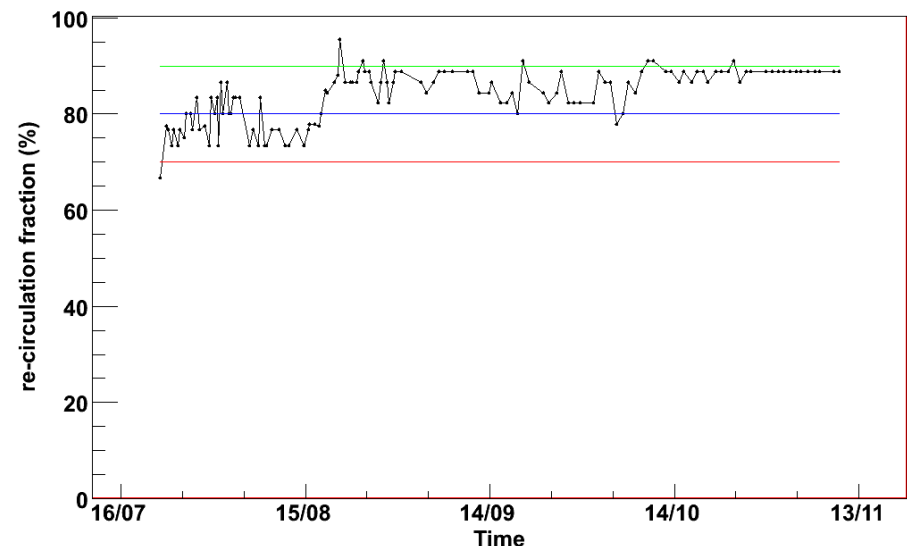

Example from a test cycle

All the DGs were stable operated for about 3 months

If the “air” concentration in the mixture is much greater than 500 ppm the performance (i.e. current) starts to be affected

Beginning of November: sudden increase of the current in all the DG operated in closed loop mode (particularly evident for the gap up)

Reference DG working in open mode

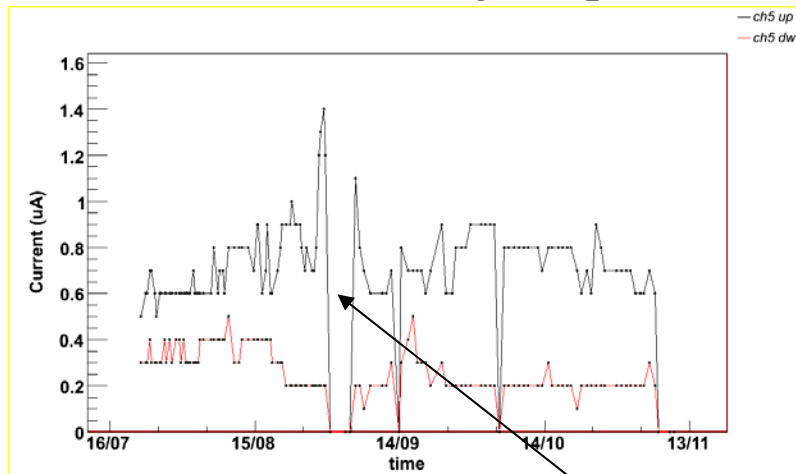

DG working in re-circulation mode

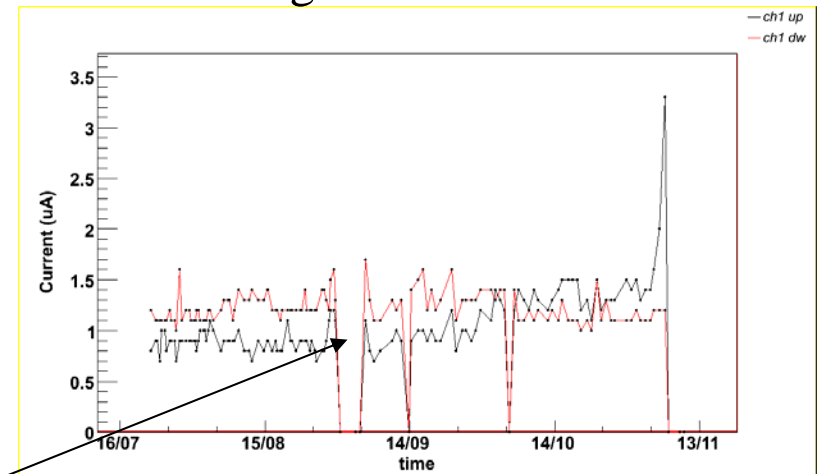

**Abnormal “air” level in the mixture (due to R134a cylinder impurity)
→ RPCs switched off**

Objectives

- Understanding RPC-irradiated gas mix
 - Concentration of impurities
 - Identification of harmful impurities
- Systematic understanding of purifier agents
 - Filters capacity, efficiency
 - Overall lifetime
 - Optimal filter combination, etc
 - Try new filters?
- Final optimization of LHC closed-loop gas systems operation

Set-up (status June 2008)

- Main users of GIF till end of 2008, possibly also in 2009 ✓
- Set-up:
 - 5 (+1) CMS Double Gaps (HV P.S, SW, etc) ✓
 - Refurbished ATLAS GIF Gas system ✓
 - new Filters rack ✓
 - Gas Analysis: GC/MS ✓
 - Fluoride measurement ✓



Detectors

5 (+1) CMS-RPC double gap

Leak test performed
after installation

GIF source at about
2.5 m from RPC.
If needed we will tune the radiation
using max ABS2

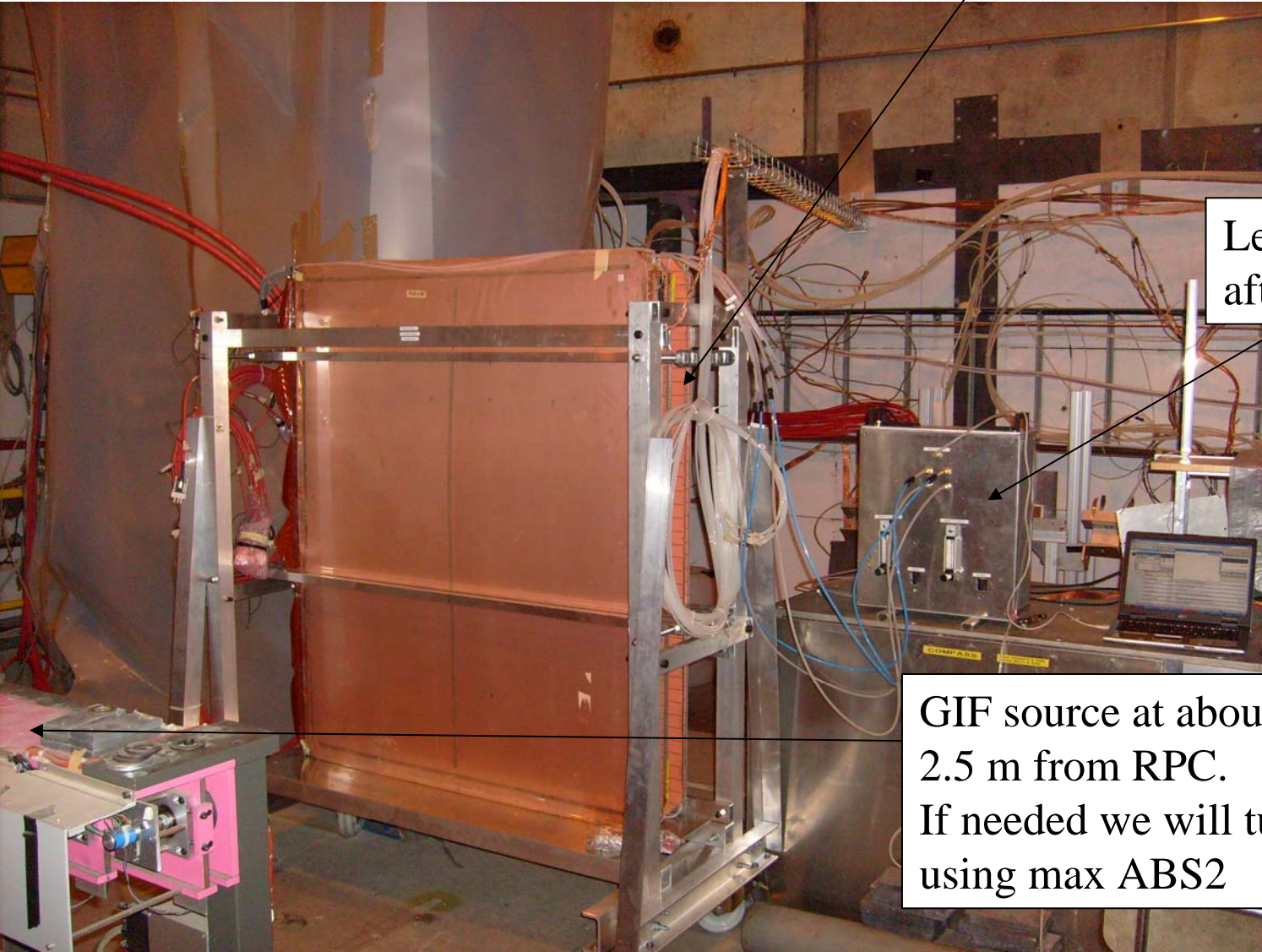

High voltage system



The high voltage system is just outside the radiation area.

SY1527 + 2 HV modules + HV cables have been provided by CMS

Gas System Racks Layout

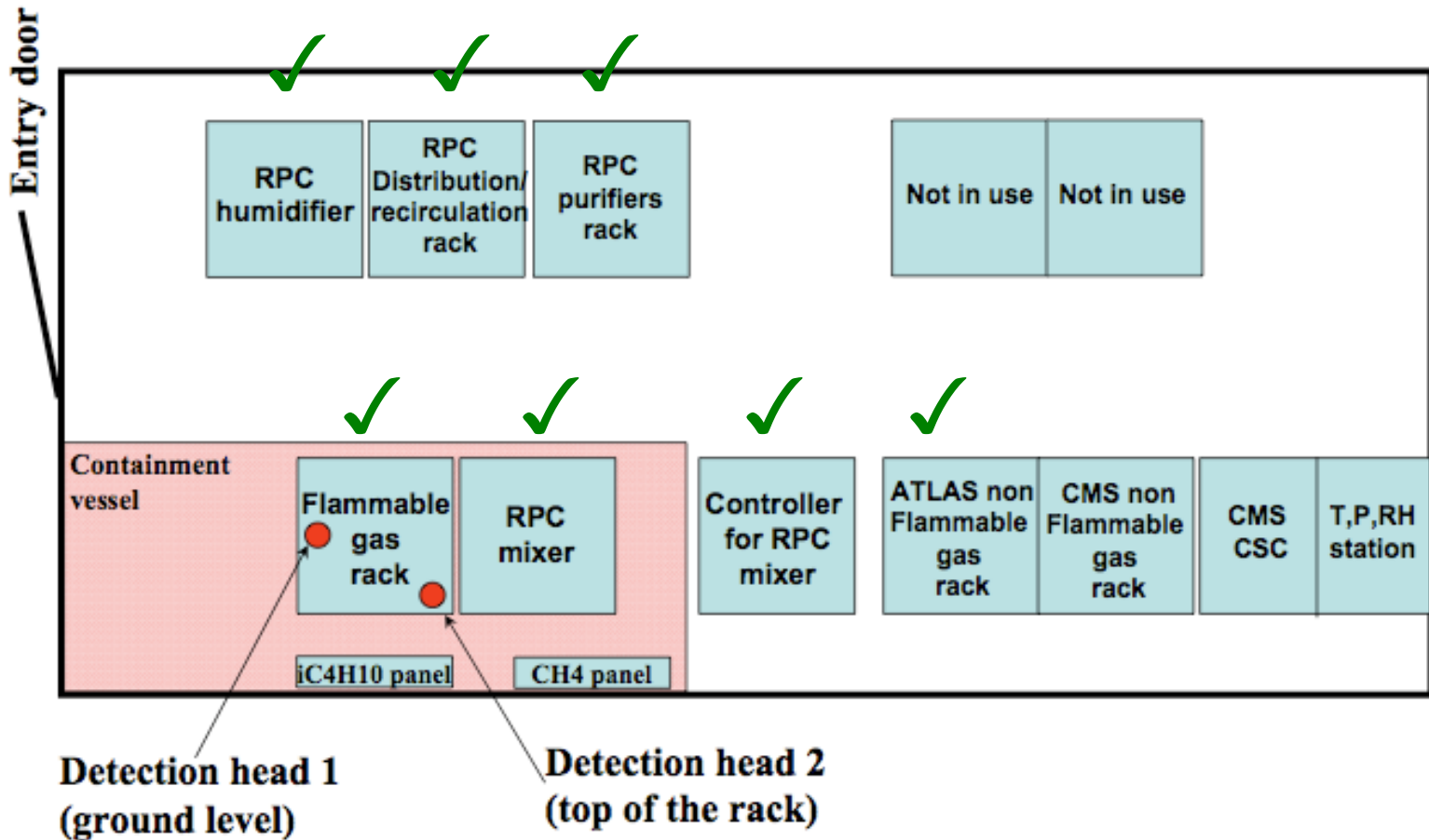

- All pipes and racks have been tested for leak tightness (30' at constant P)
- Pipes from gas panel to chambers inside GIF and return are new (rilsan)
- When needed, (many) rubber joints have been replaced
- MFCs have been re-calibrated

Gas system



Gas re-circulation rack (from ATLAS). During the first phase of the test we will use the system in open mode. The gas from the RPC will be sent to the filters rack and then vented.

Filters rack (PH-DT).
6 rotameters for the gas distribution to the chambers
6 cartridges with different purifier agents
6 rotameters for the gas distribution to each cartridge

Gas system layout

ATLAS re-circulation rack

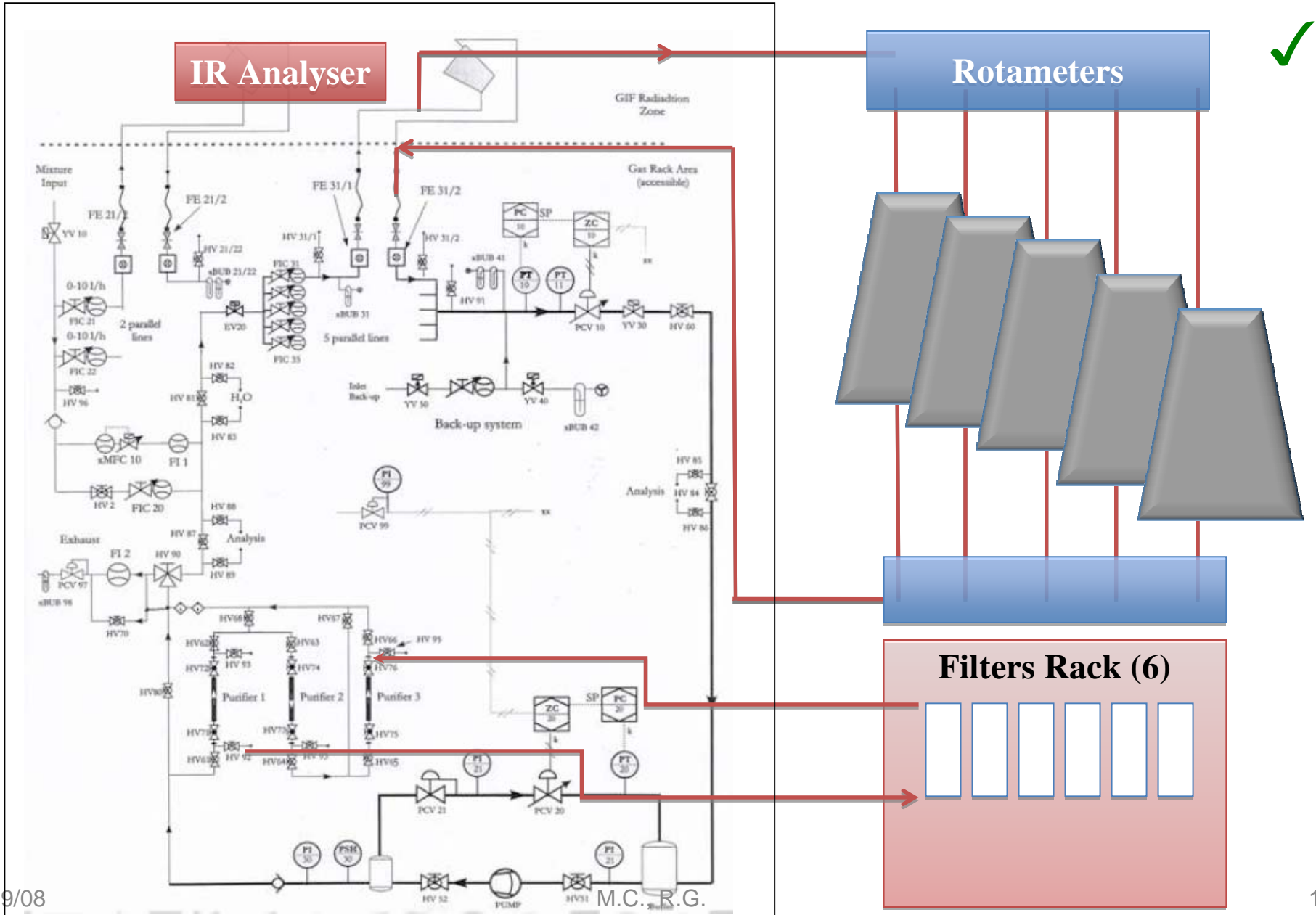

Filters Rack

Pickage for Analysis

Example of connection 'a la carte'

Outlet of chambers

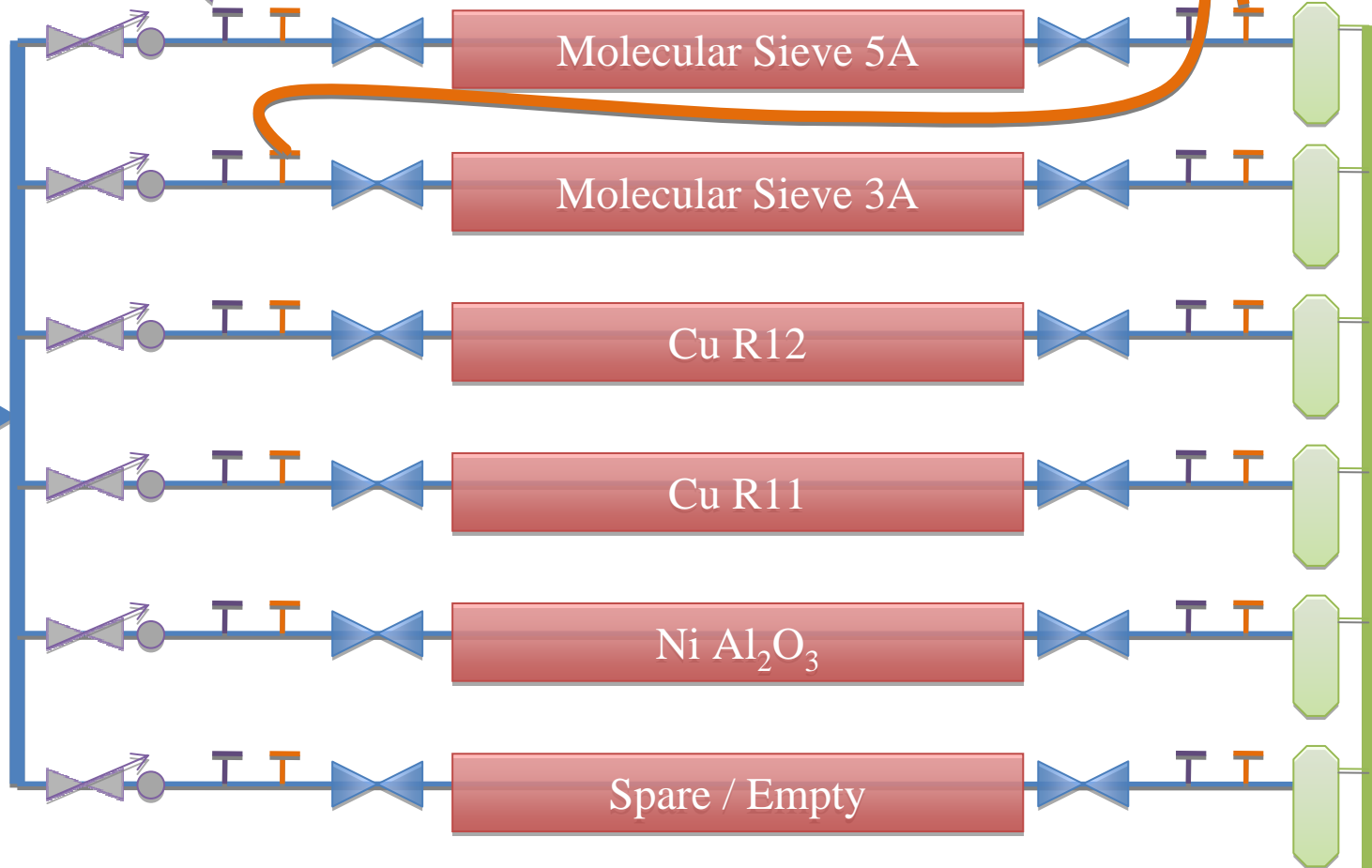

Exhaust

Status of the test

1. Checked chamber performance with radiation → June-July ✓
2. Make reference Bakelite resistivity measurements → July ✓
3. Set-up F-measurement and scan HF concentration for different concentrations of iC_4H_{10} and SF_6 → July ✓
4. Study of the production of other impurities as a function of the gas mixture composition → August
5. Perform detailed gas analysis of every filter individually (comparison fresh mixture vs purified mixture) → September

Status and planning

6. Split the return gas into the different purifier agents and start the study of the lifetime for several cycles (6-10 regenerations) → October - June
7. Test of possible new material (more specific for the identified impurities) → October – June
8. Start to test the old and new purifier configurations in closed loop circulation → June-December

Analysis of fluoride and other impurities

We are studying the production rate of F- and other impurities in order to verify if a small change in the mixture composition can produce a significant reduction of the production rate.

tot Flow: (l/h)	C2H2F4 (%)	iC4H10 (%)	SF6 (%)	date start	date end	8800 (V)	9000 (V)	9200 (V)	9400 (V)	9600 (V)	9800 (V)
40	96.35	3.5	0.15								
40	96.2	3.5	0.3								
40	95.9	3.5	0.6								
40	94.85	5	0.15								
40	94.7	5	0.3								
40	94.4	5	0.6								
40	92.85	7	0.15								
40	92.7	7	0.3								
40	92.4	7	0.6								

✓ (F-)

On going with GC-MS for other impurities

Fluoride study

The F- production rate is measured with two different techniques: ISE and HPLC

**Ion Selective Electrode for F-:
On-line measurement
(now with a double channel station)**

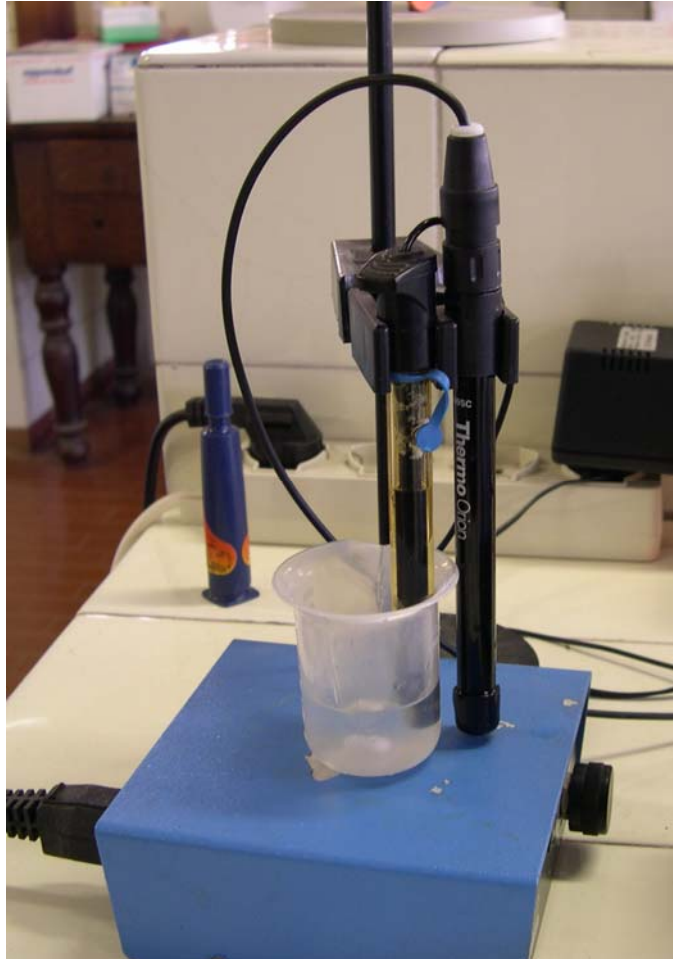

**High Performance Liquid Chromatography:
Cross check + will allow to spot-out other impurities**



Fluoride study

Results from CMS GIF ageing test

(R.Guida et al., Nucl. Instr. and Meth. A (2008), doi:10.1016/j.nima.2008.06.009)

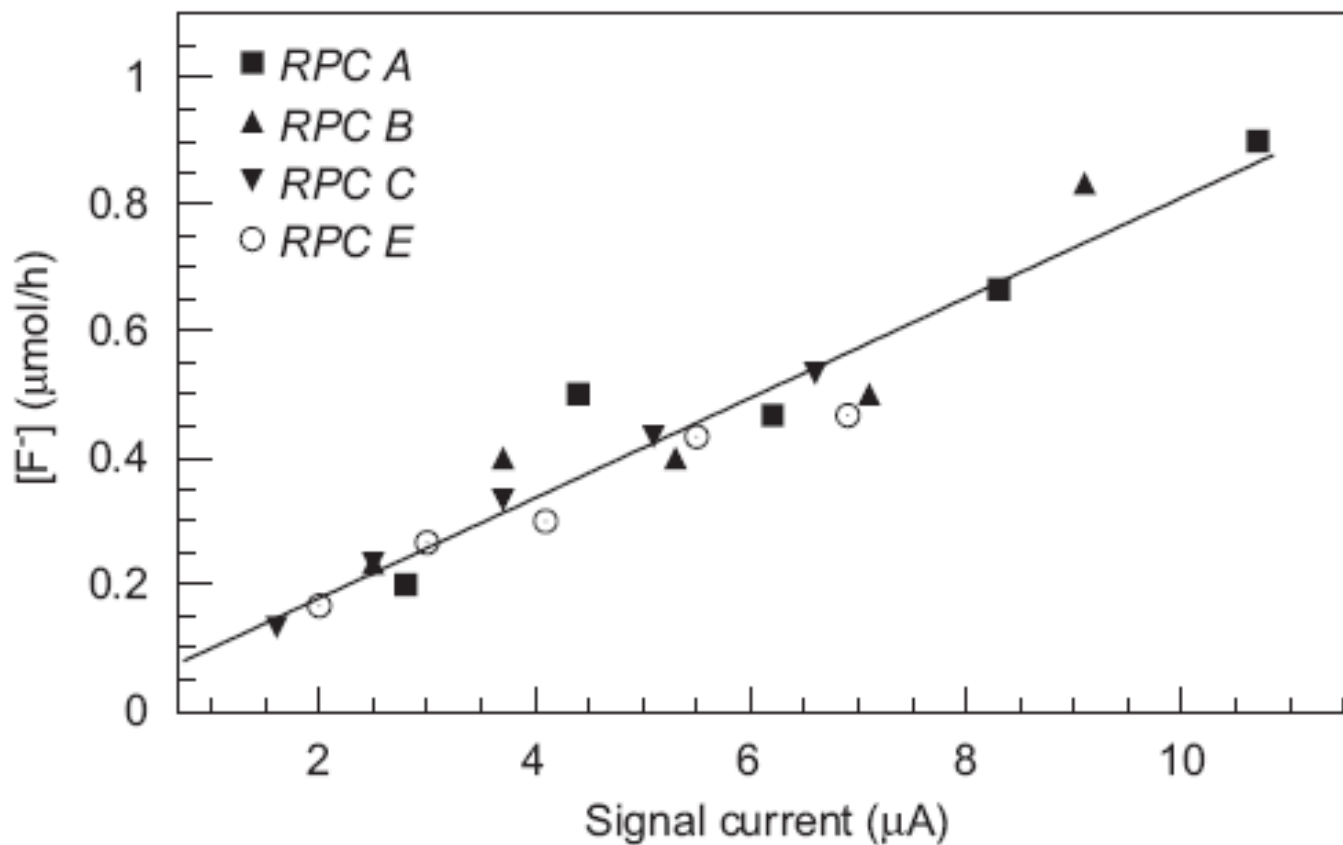

Fluoride production study: new results

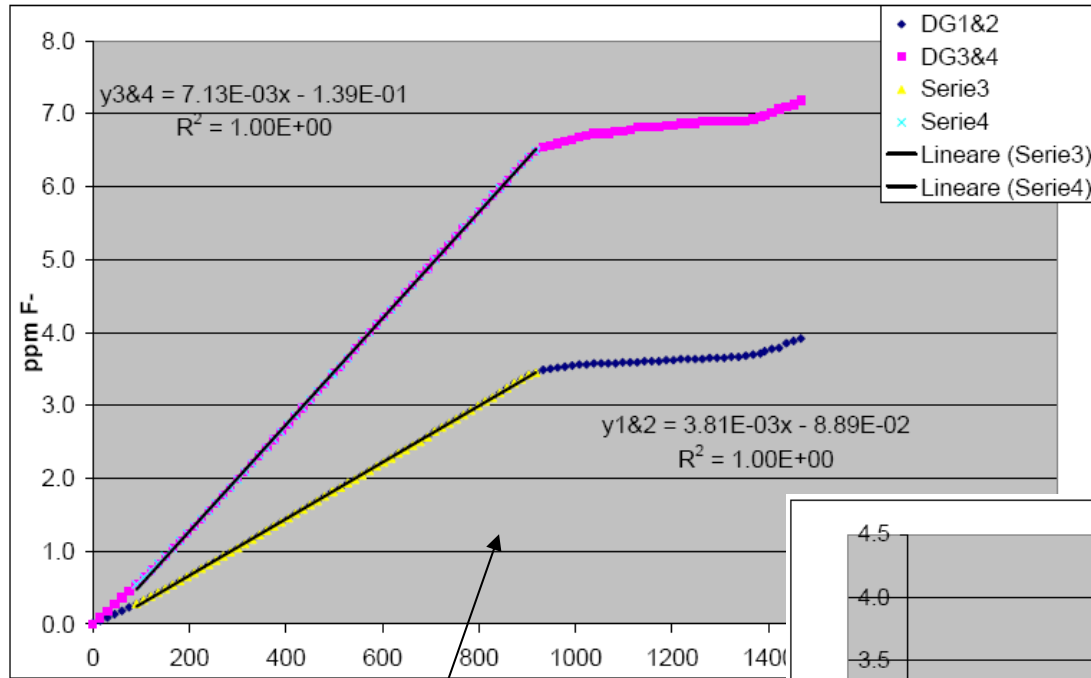

Raw data:

Fluoride accumulation vs time

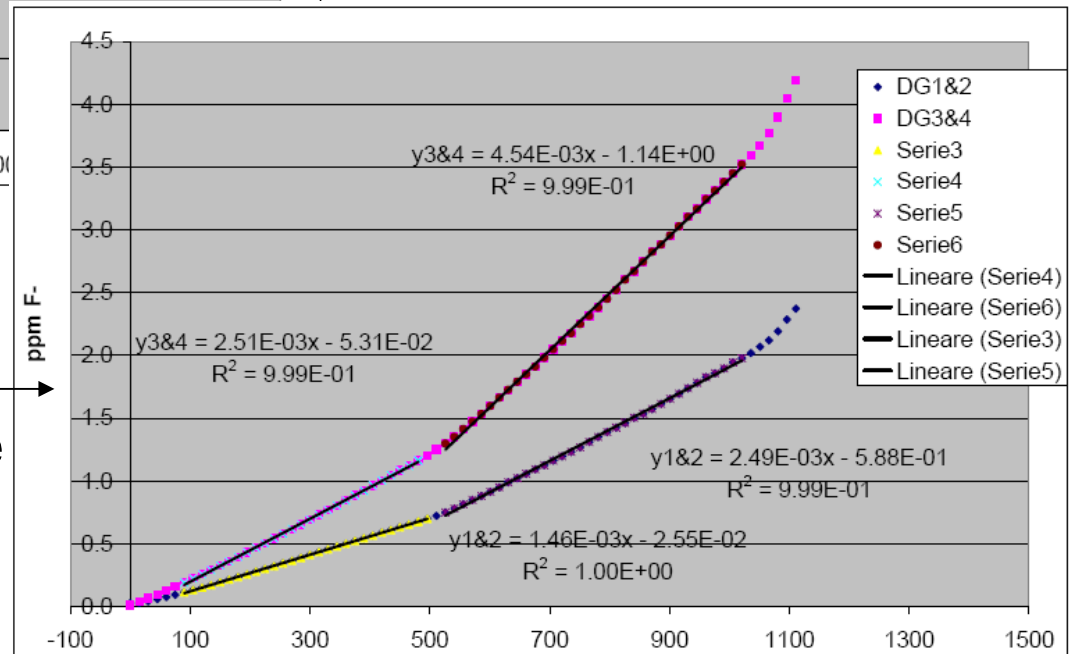

Fluoride production study

Fluoride production rate vs detector high voltage:

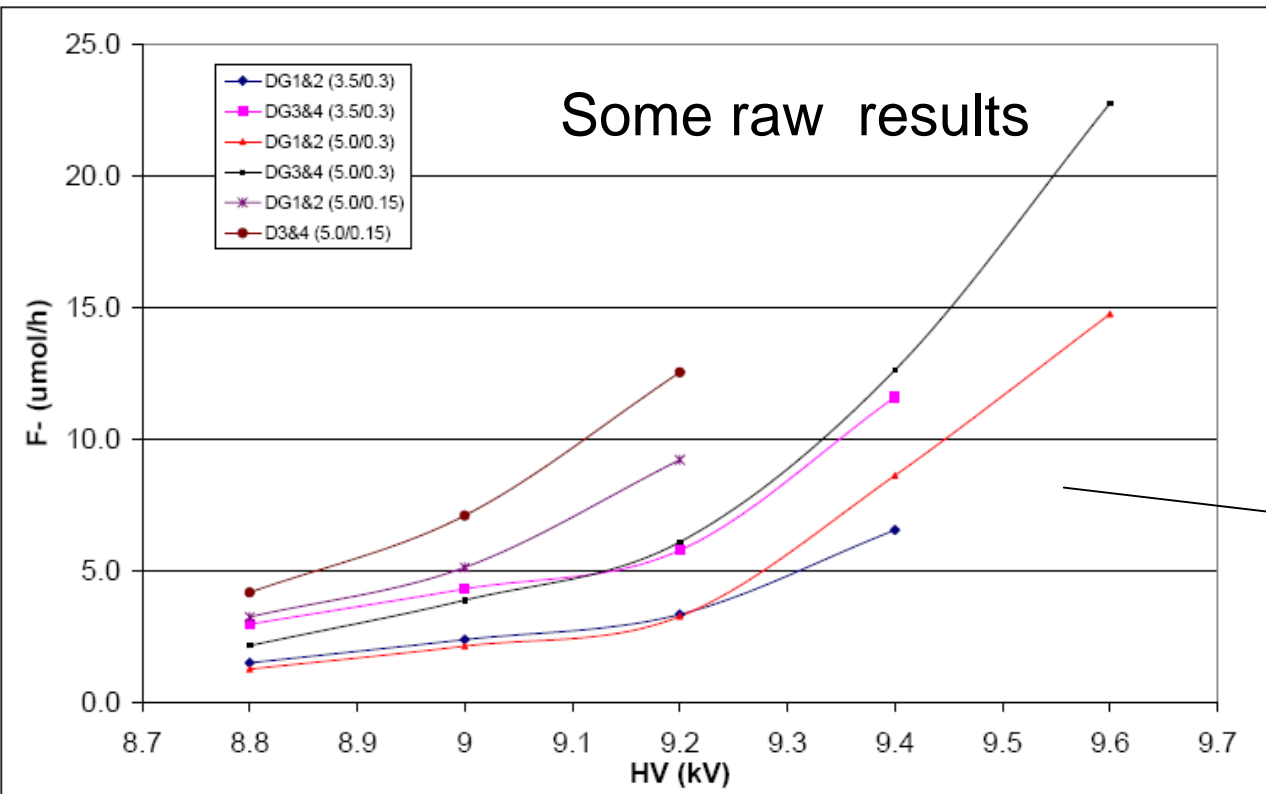

Final results:

F- vs current

F- vs efficiency

Impurities found with GC-MS

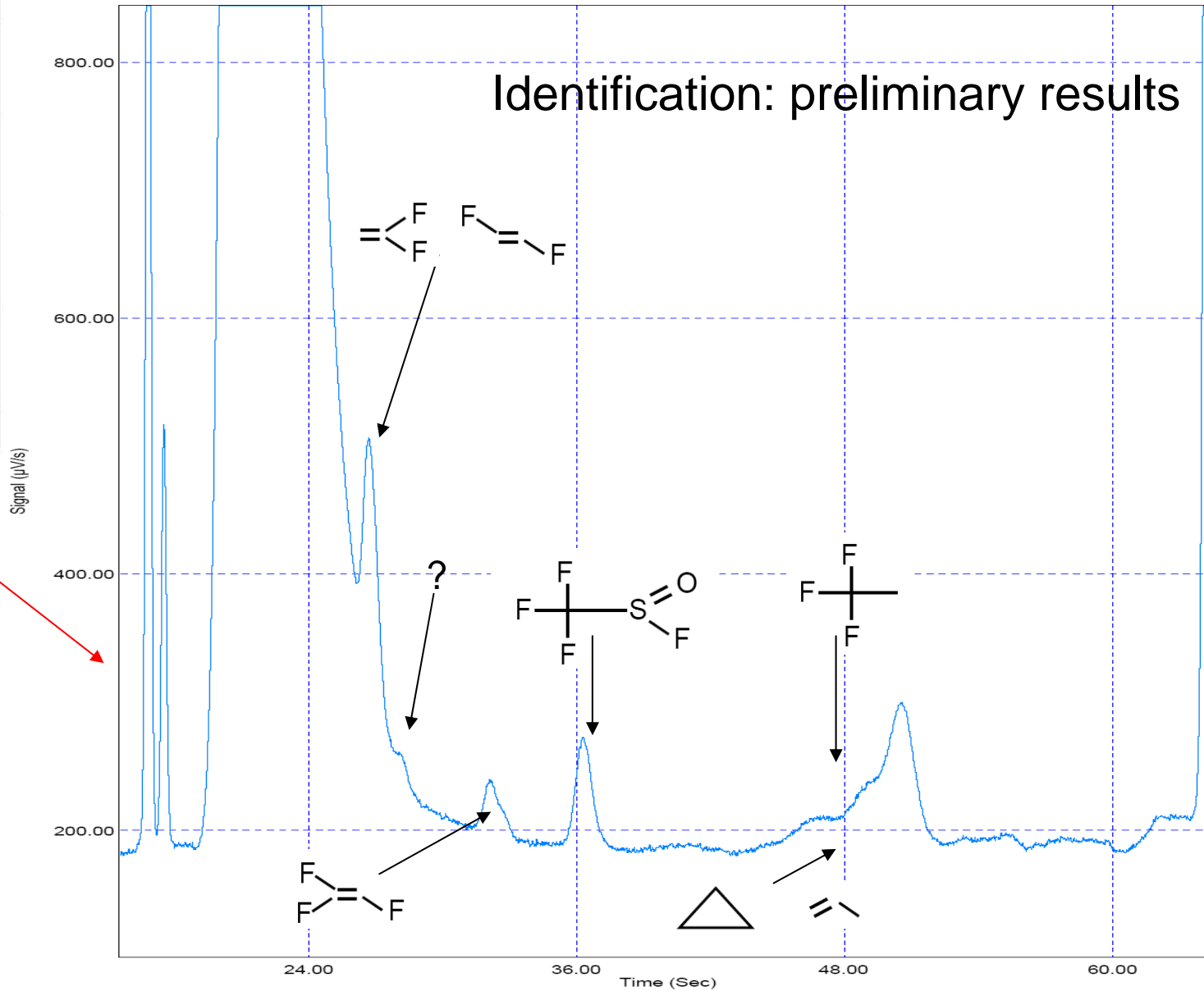
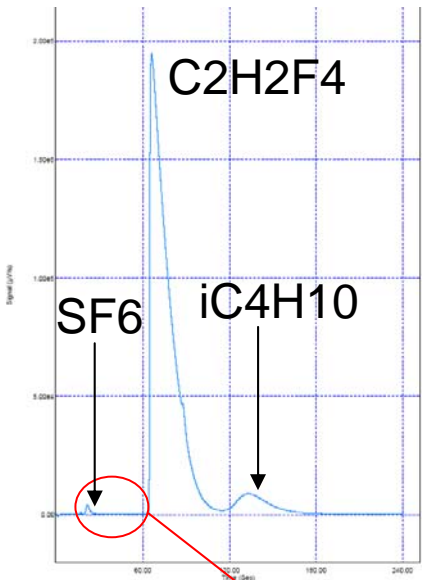

Other impurities with GC-MS

Next step (already on going) is to fill the previous table for the different mixture compositions and different high voltage (efficiency)

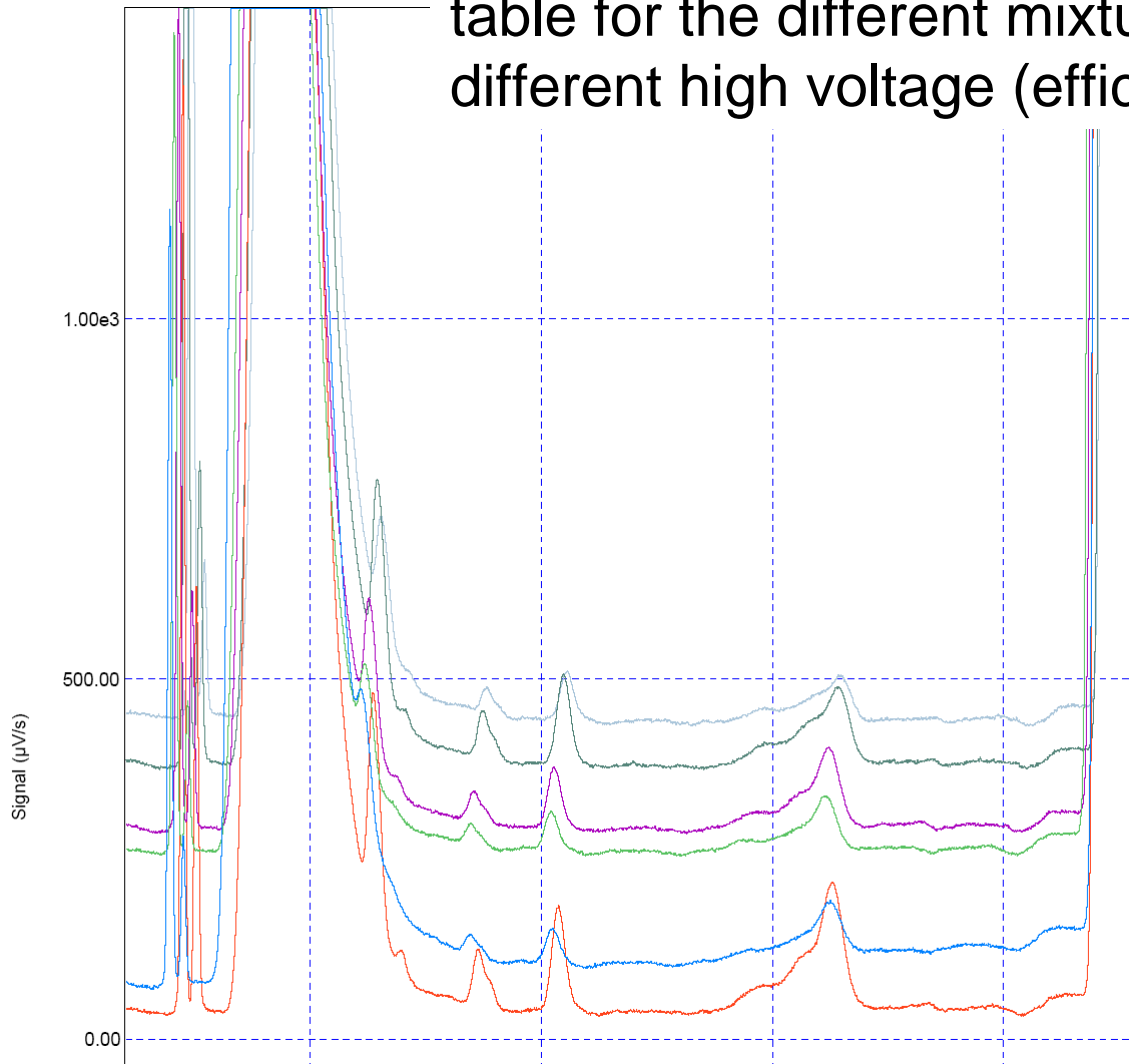

Impurities seen on the GC-MS as a function of mixture composition and detector efficiency